

Audio Player Lab

for Digital Fundamentals

A presentation of eSyst.org



Audio Player Lab Objectives

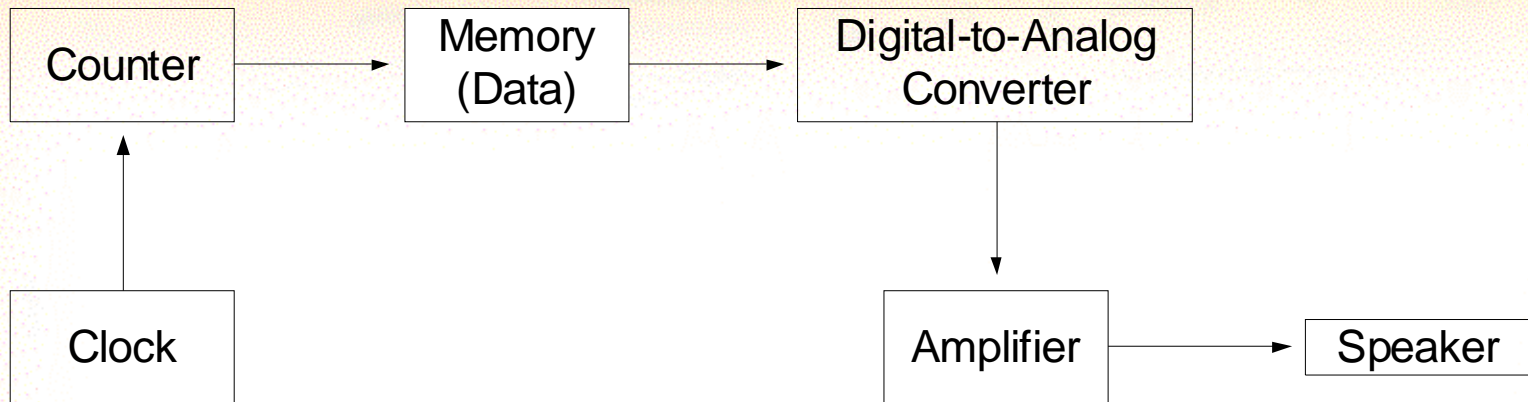

- Bridges the gap between computers software (data) and hardware.
- Exposure to clock, counter, memory, D/A converter, and amplifier circuits.

Clock Circuit

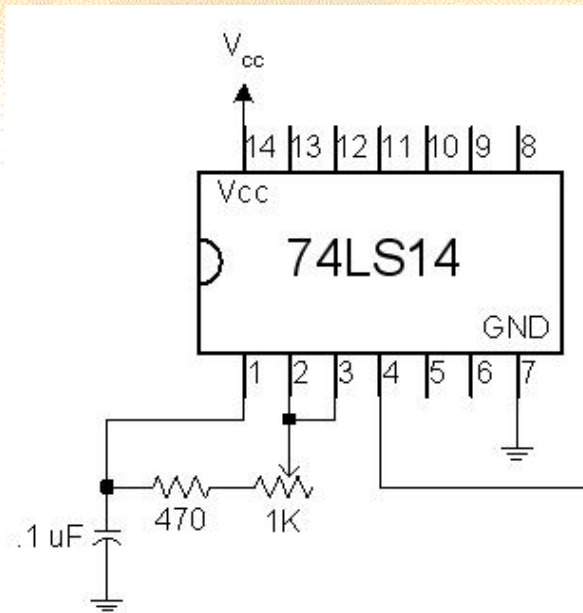

- RC Time Constant
- Inverters
- Current Flow

The Counter

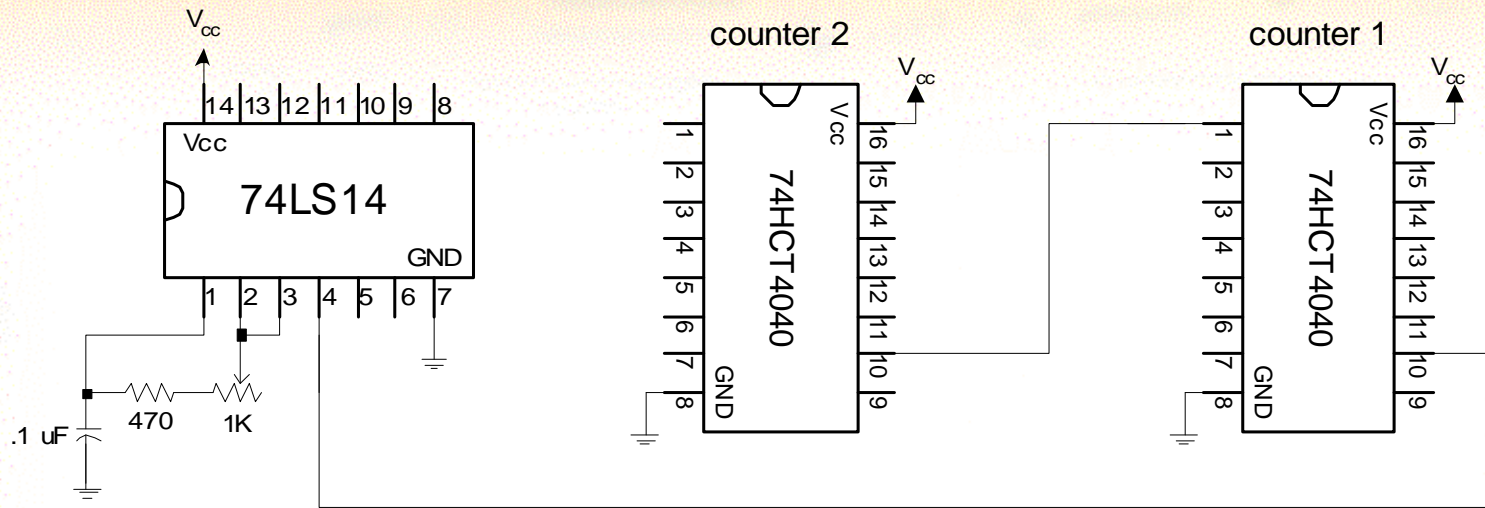

- Cascaded 74HCT4040s
- Address lines
- Resetting

Memory Chip

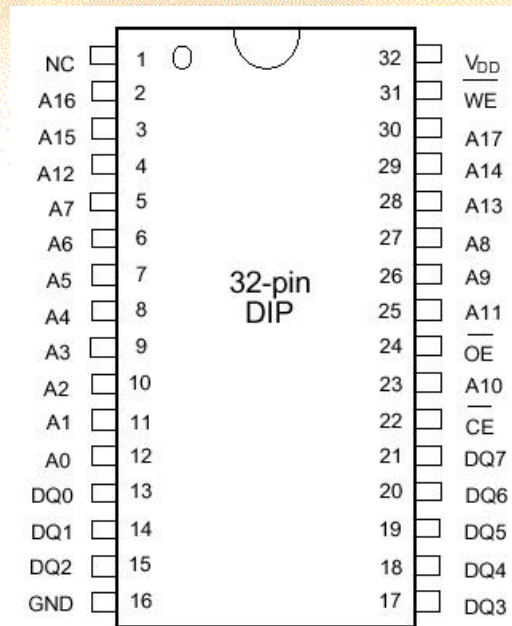

- 27C020 or 29C020
- 18 Address Lines
- 00000h – 3FFFFh

Digital-to-Analog Converter

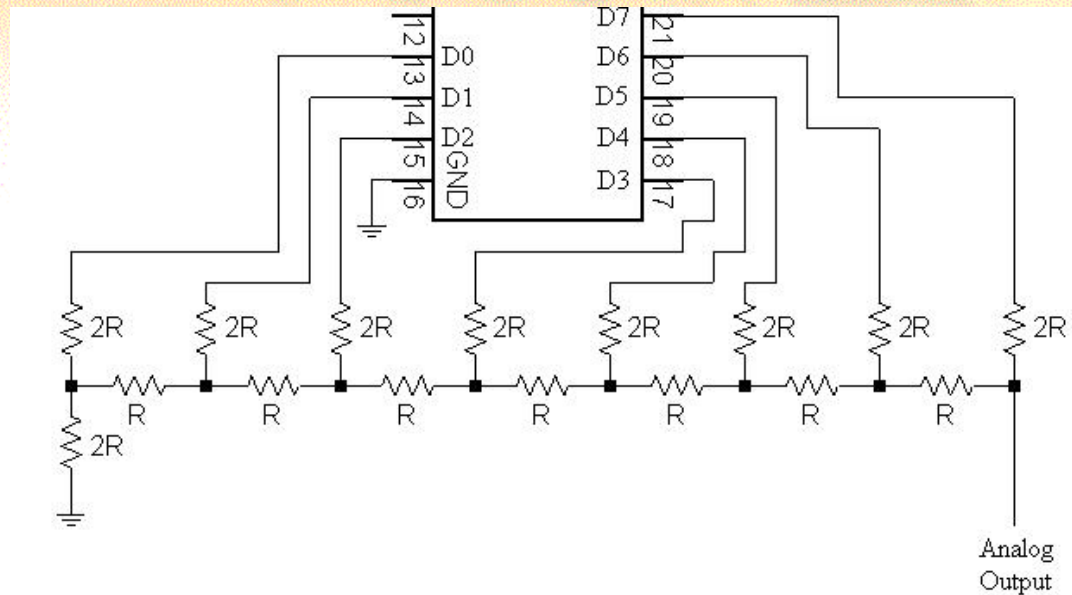

- Resolution
- Voltage Resolution
- R2R Ladder Network

Amplifier Circuit

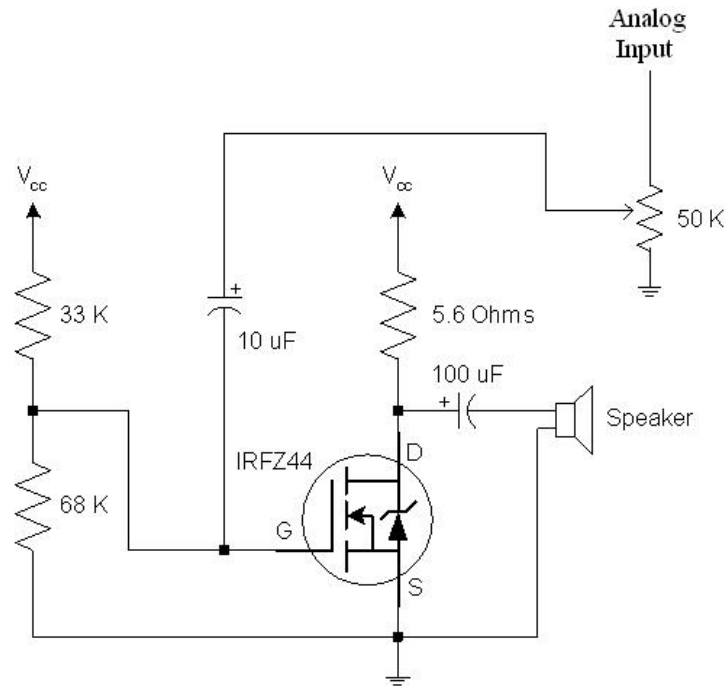

- Class A amplifier
- DC Block capacitors
- Biasing

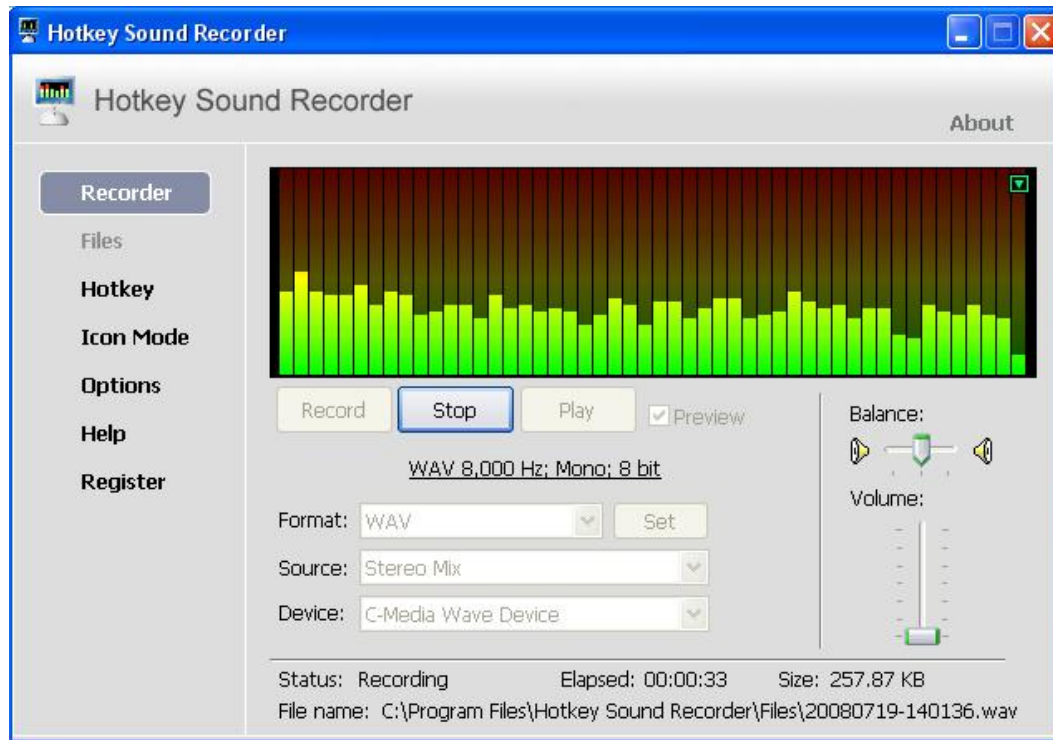

- 8-bit, mono, 8 KHz Sampling rate – 32 secs
- 8-bit, mono, 16 KHz Sampling rate – 16 secs

Wave File Header

```
2008-07-18 01h16m57s.wav - HHD Software Free Hex Editor
File Edit Tools Select Window Help
C:\2008-07-18 01h16m57s.wav
Hex
00000000: 49 46 46 2c 78 00 00 57 41 56 45 66 6d 74 20 RIFF,x..WAVEfmt
00000010: 10 00 00 00 01 00 01 00 40 1f 00 00 80 3e 00 00 .....@...e>..
00000020: 01 00 08 00 64 61 74 61 00 78 00 00 80 80 80 80 ...data.x...eeee
00000030: 80 80 7f 80 80 7f 80 80 7f 80 80 7f 80 7f 80 7f eeeeeeeeeeeeee
00000040: 80 7f 80 7f 80 7f 80 7f 80 7f 80 7f 80 7e 7b 7a eeeeeeeeeeee~{z
00000050: 7d 7c 79 7a 7a 7a 7a 7b 7c 7c 7b 7a 79 7a 7c 7e }|yzzzz(|{|z|~
00000060: 80 81 82 82 83 85 87 8a 8c 8d 8c 8a 88 85 81 7e e|,,f..+SSES^..Q~
00000070: 7c 7b 7a 78 76 75 74 74 75 76 79 7b 7b 7c 7d 81 |{zxvuttuvy({|}Q
00000080: 84 87 89 8b 8e 90 91 92 94 95 92 8f 8b 88 85 82 ,,+%<ZQ''^'Q<^...
00000090: 7d 7a 79 77 76 74 72 72 73 74 75 75 75 75 76 78 }zywvtrrstuuuvx
000000a0: 7a 7d 7e 7f 82 85 89 8c 8f 90 90 8f 8d 8a 88 87 z)~Q,,%QSQS^+
000000b0: 86 84 82 7f 7c 7b 7a 7a 7c 7d 7d 7d 7c 7a 79 7a +,,Q|{zz|})|zyz
000000c0: 7c 7e 80 81 82 83 84 86 89 8a 8a 88 86 84 82 82 |~e|,,f..+SSt,,
000000d0: 80 7d 7c 7c 7b 7a 79 79 7b 7c 7c 7b 79 78 78 79 e|{|z|y|{|yxy
000000e0: 7b 7d 7e 7f 81 84 87 89 8c 8e 90 8f 8e 8b 89 86 (}~Q,,+eZQZ<%t
000000f0: 84 81 7e 7b 79 78 78 79 7a 7b 7c 7c 7b 7a 79 7a ..Q~{yxyz{|{|z|
00000100: 7c 7e 80 81 82 82 84 86 88 8b 8d 8c 8b 89 86 83 |~e|,,+t^cQk%tf
00000110: 81 7d 7a 7a 79 77 74 73 74 74 75 77 77 78 79 7a Q}zywtsttuwxyz
00000120: 7d 80 82 84 86 89 8c 8e 91 93 95 95 93 90 8c 88 }e,,+tQZ''..^Qe^
00000130: 84 81 7d 7b 79 77 76 74 73 73 74 75 75 75 74 74 ..Q|{ywvtsstuuutt
Ready Pos: 0x00000000 of 0x0000782c Sel: 0x00000000 - 0x0000002c OVR.
```

- 00000h – 0002Bh.
- Header must be removed.

Audio Player Circuit

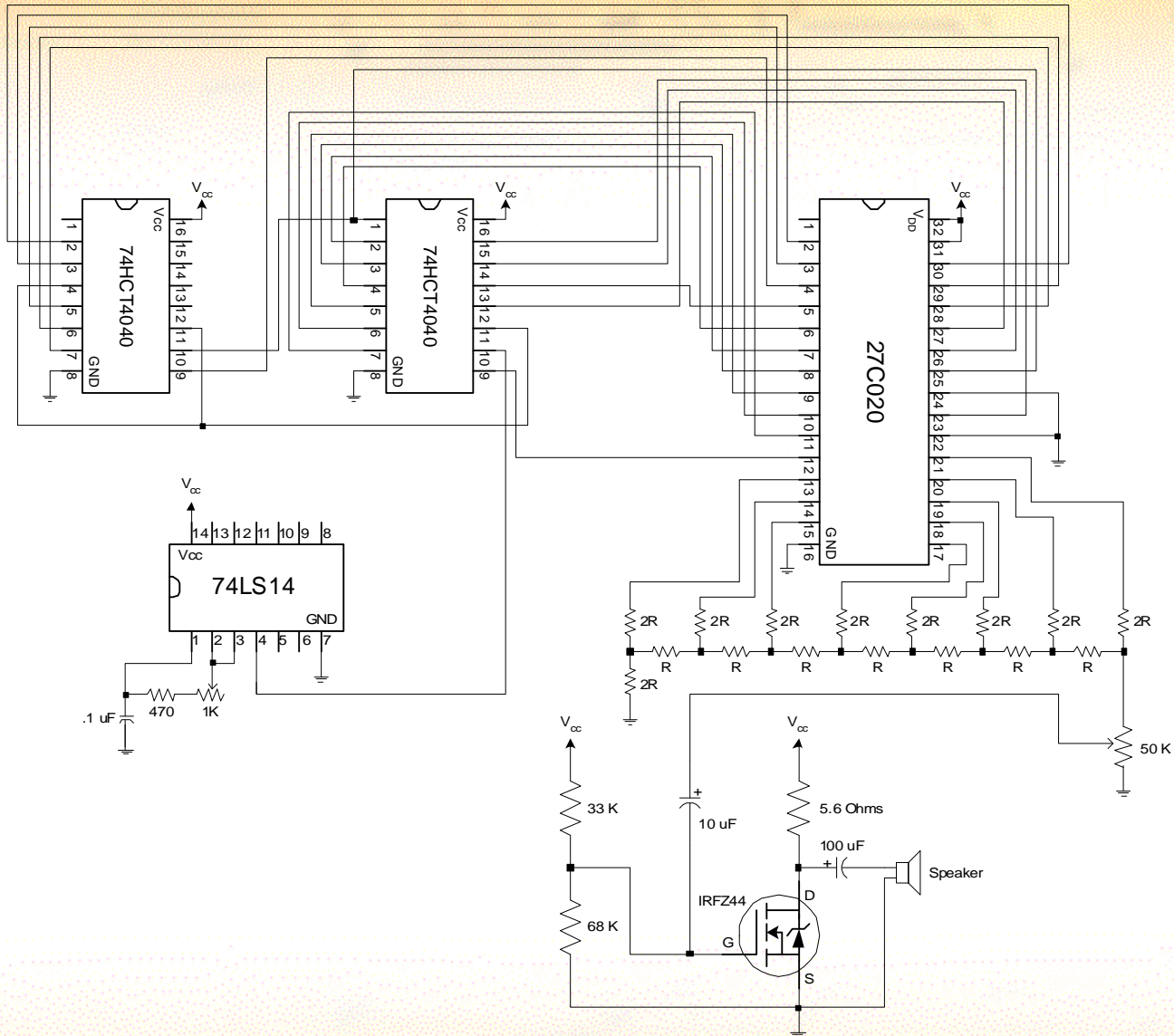

PC Board Proto-Type

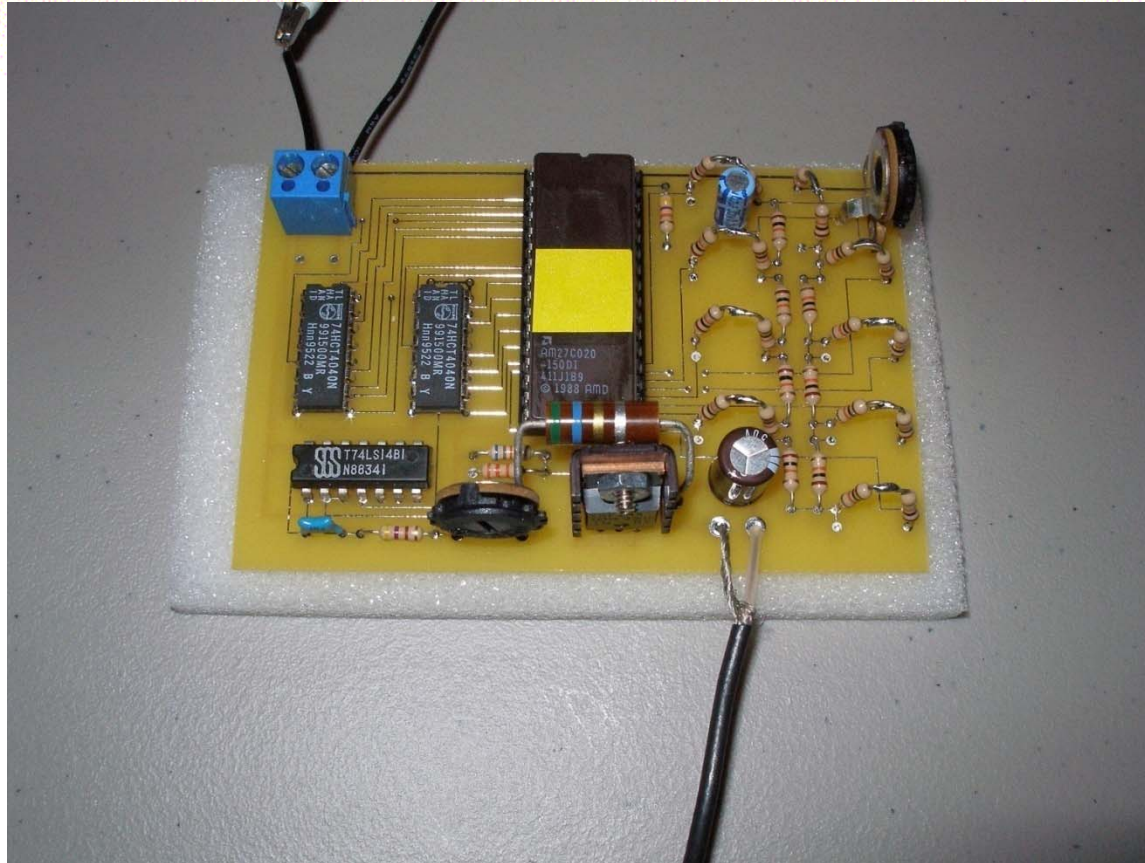

**Demo
and
Thank You**